

► Threaded sleeve for incorporating a leveling foot or castor. For further information (see page 208)

| D28L threaded sleeve (PA) | ESD | No. |
|---------------------------|-----|----------------------|
| | 20 | 3 842 541 185 |

Material: PA66 (conductive); black
Hexagon nut: aluminum

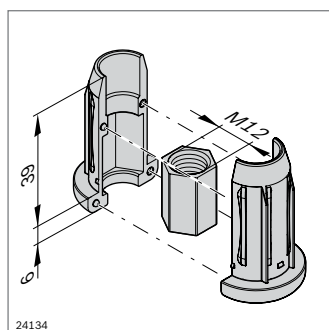
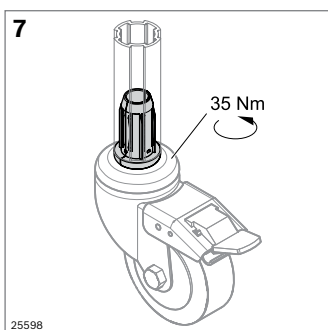

| D28L threaded sleeve (Zn) | ESD | No. |
|---------------------------|-----|----------------------|
| | 20 | 3 842 548 119 |

Material: diecast zinc
Hexagon nut: aluminum

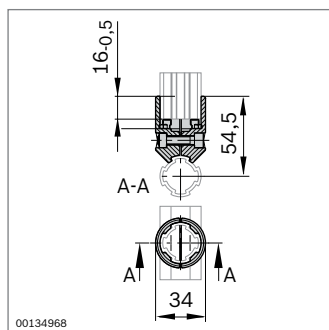
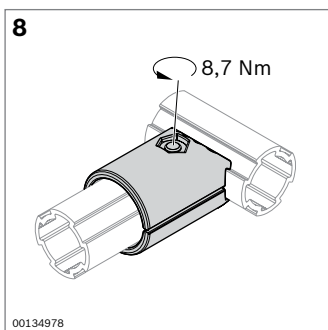

| 90° connector | ESD | No. | FS |
|---------------|-----|----------------------|-----|
| | 20 | 3 842 541 173 | FS1 |

Material: diecast zinc
Scope of delivery: includes fastening material (FS)

FS1

- ISO 4762 M6x25
- ISO 10511 M6

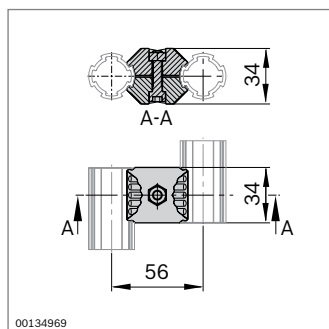
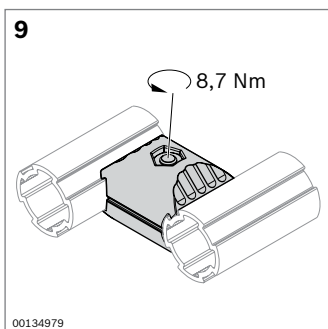

| Parallel connector | ESD | No. | FS |
|--------------------|-----|----------------------|-----|
| | 20 | 3 842 541 183 | FS1 |

Material: diecast zinc
Scope of delivery: includes fastening material (FS)

FS1

- ISO 4762 M6x25
- ISO 10511 M6

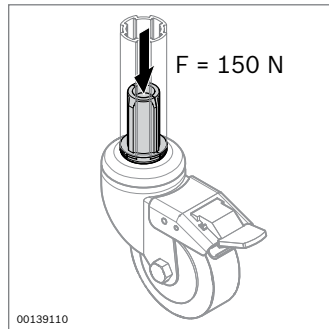
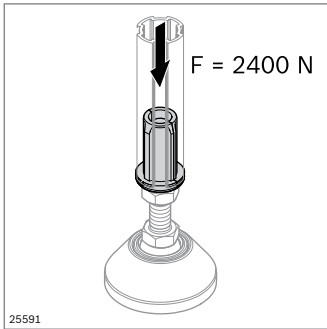

D28L threaded sleeve (PA)

Permissible bearing load

Material shuttle is approved for 60 kg

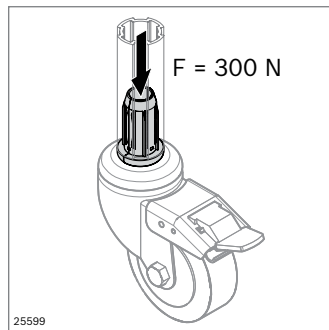
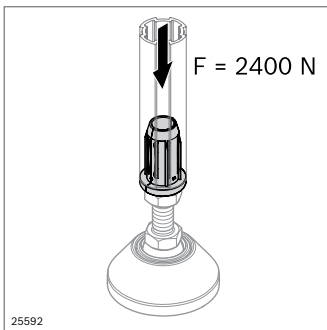

D28L threaded sleeve (Zn)

Permissible bearing load

Material shuttle is approved for 100 kg

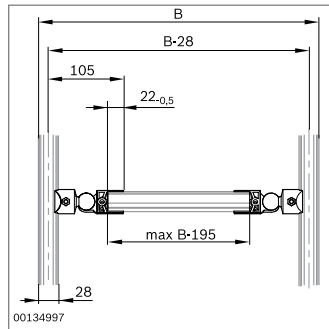
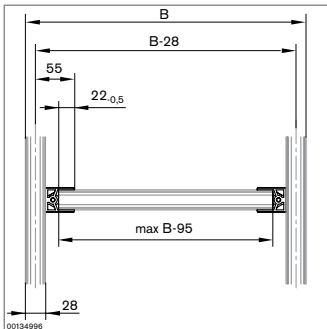

Length calculation

