

Electric case lifters

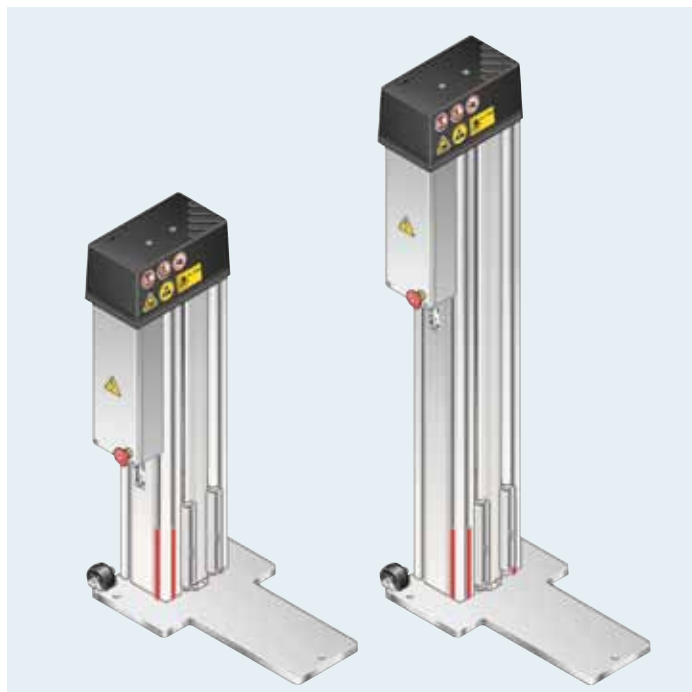

- ▶ Ergonomic parts supply at the workstation
- ▶ Operating mode:
 - Manual: lifting and lowering through hand switch actuation. Suitable for use with Basic and Comfort hand switches
 - Automatic: automatic lifting and lowering. Suitable for use with Comfort hand switches in conjunction with Comfort sensor unit (retrofit possible)
- ▶ Rollers for semi-mobile use at various workstations
- ▶ ESD version for use in ESD-sensitive areas
- ▶ The 10 mm slot enables simple mounting of components from the Basic Mechanic Elements modular system
- ▶ Easy setup without electrician; connection via HD mains cable (see page 155) or connecting cable (see page 49)

Required accessories: Basic hand switch or Comfort hand switch + Comfort sensor unit; mains cable
 Recommended accessories: attachment plate, forks, suspension lug (see pages 156, 157)

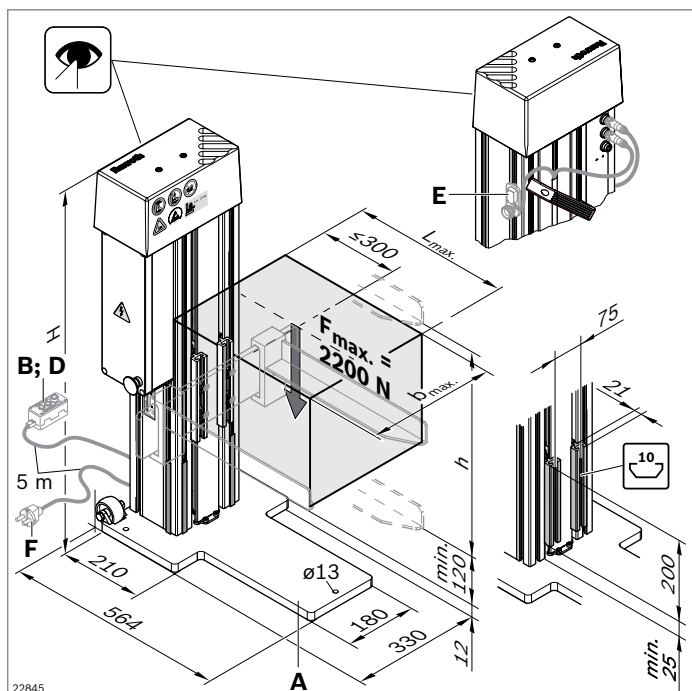

Technical data

- ▶ Permissible load F_{max} : 2200 N
- ▶ Lifting velocity: 25 mm/s
- ▶ Operating time (OT): 20%
- ▶ Connection: ~230 V/max. 16 A
- ▶ IP rating: IP 40 IEC 529

		Max. permitted load bearing surface		$b_{max} \times L_{max}$	
Attachment plate B = 450 mm				400 mm x 600 mm	
Attachment plate B = 650 mm				600 mm x 400 mm	
		h (mm)	H (mm)	ESD No.	
A	Electric case	EU ¹	900	1300	⚡ 3 842 546 992
	lifter	USA/	1300	1700	⚡ 3 842 555 641
		CDN			

¹ TÜV, UL and CSA test marks