

Flocked chain

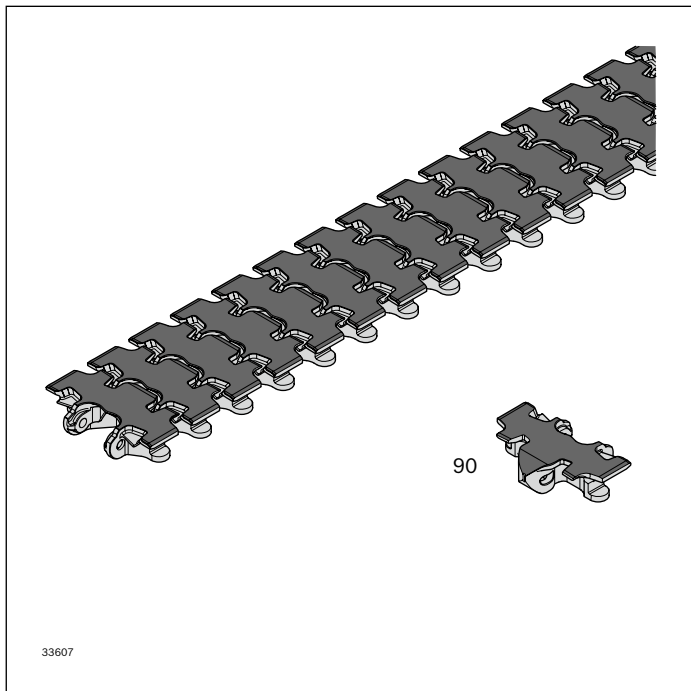

The flocked chain is used on sensitive transport surfaces (e.g. gloss, clear, barcode, raised printing).

- Transport on ascending or descending sections up to 7° possible, depending on the product (test required)
- For products susceptible to jams
- Only dry use
- Maximum permissible tracking force: 5 N/chain link
- Maximum chain tensile force: 1250 N
- Size: 90
- Not suitable for sharp-edged products
- Combination with chain links of different chain types is not permitted

Note:

Not suitable for standard VarioFlow *plus* WT system.

- ▶ Soft PA-flocking 3.3 dtex for sensitive product surfaces
- ▶ Extremely quiet chain running thanks to the patented chain design

Scope of delivery:

Chain: Complete, incl. chain pin and jointed bolts

Condition on delivery:

Chain: Fully assembled

Material:

- Chain link: POM, white
- Flocking: PA 3.3 dtex, anthracite
- Chain pin: Stainless steel, 1.4301
- Jointed bolts: PA66

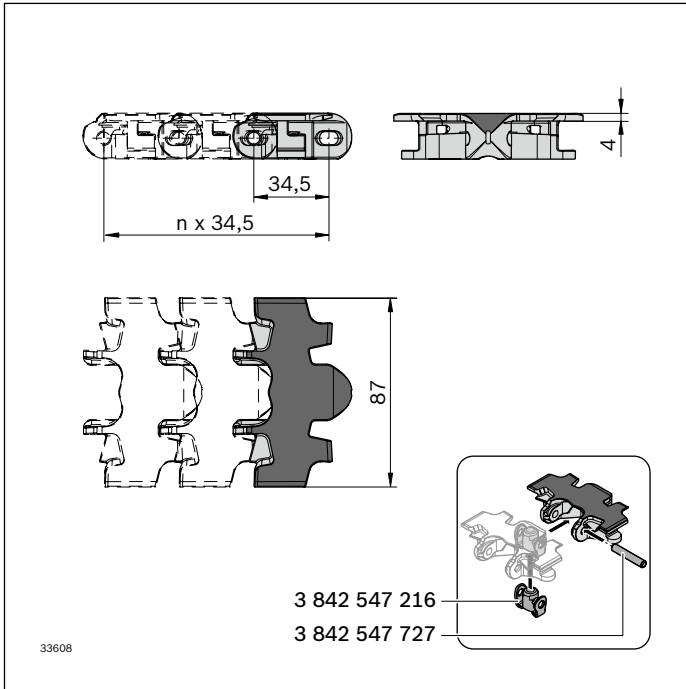

Flocked chain VFplus 90	L (mm)	No.
	4968	1 3 842 553 023