

Junction

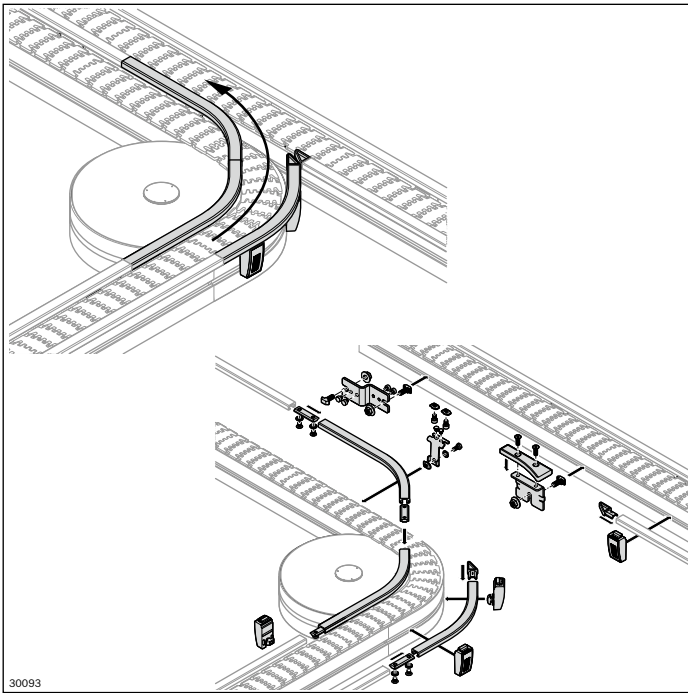

Used for the junction of different, curving conveyor sections

- Complete assembly kit to install on existing sections or curve wheels
- The support enables the workpiece pallet to move over the section gap with no danger of tipping

Scope of delivery:

Kit incl. fastening parts (as shown)

Material:

Gliding surface support: PA; black

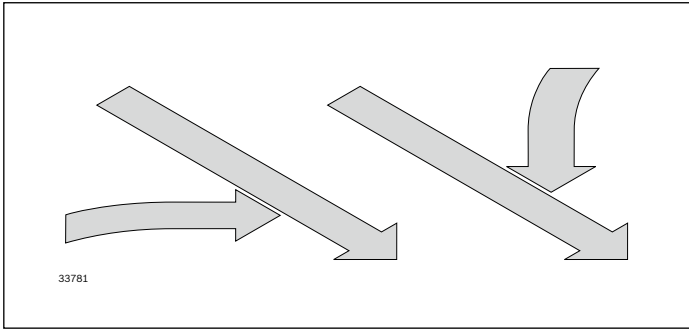

45° junction, right/left	No.
<i>VFplus 65/90</i>	3 842 551 122

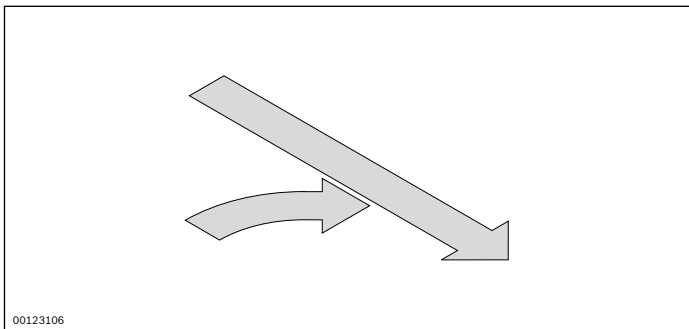

90° junction, right	No.
<i>VFplus 65</i>	3 842 551 128
<i>VFplus 90</i>	3 842 551 125

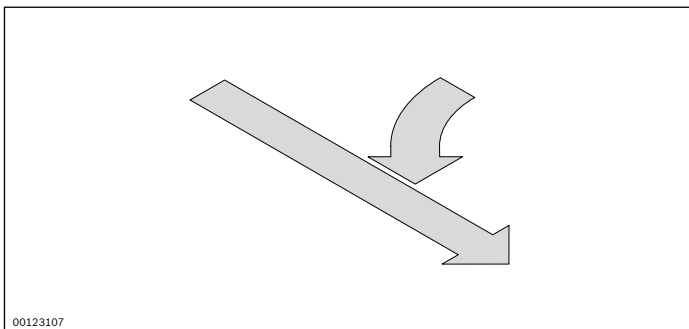

90° junction, left	No.
<i>VFplus 65</i>	3 842 551 137
<i>VFplus 90</i>	3 842 551 124

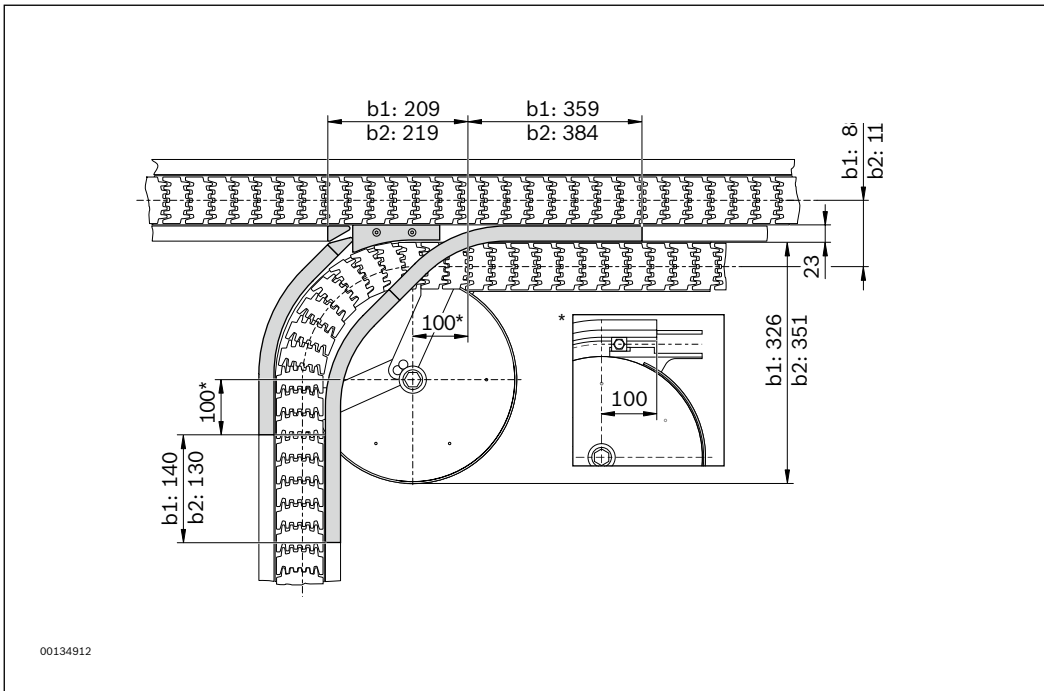
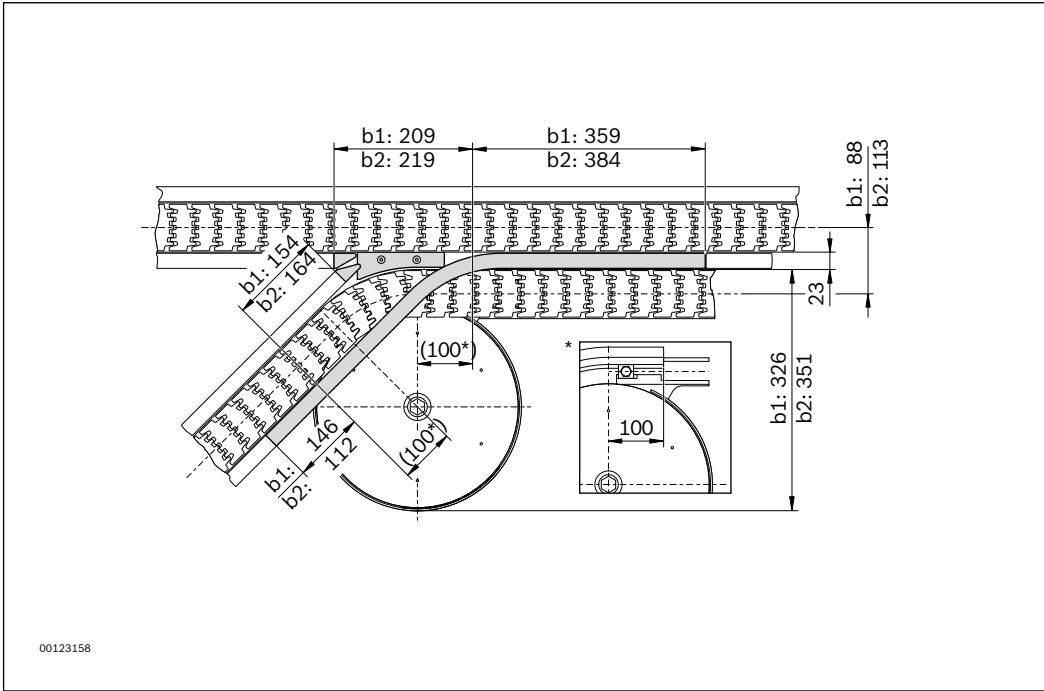

b = size;
 b1 = 65; b2 = 90