

WT plate End piece

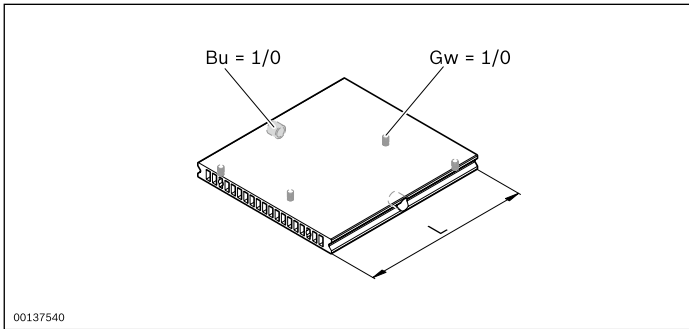

WT plate	Bu	Gw	L (mm)	No.
VFplus 65	0; 1	0; 1	30 ... 6000	3 842 996 204/...
VFplus 90	0; 1	0; 1	30 ... 6000	3 842 996 205/...

Parameters	Size	L _{min} (mm)	L _{max} (mm)
Bu = 1	65/90	125	500
Gw = 1	65	76	500
	90	114	500

Bu = 1: with holes for centering bushings for positioning in the positioning unit (centering bushings not in scope of delivery)

Bu = 0: without holes for centering bushings

Gw = 1: with holes to assemble the end pieces

Gw = 0: without holes to assemble the end pieces

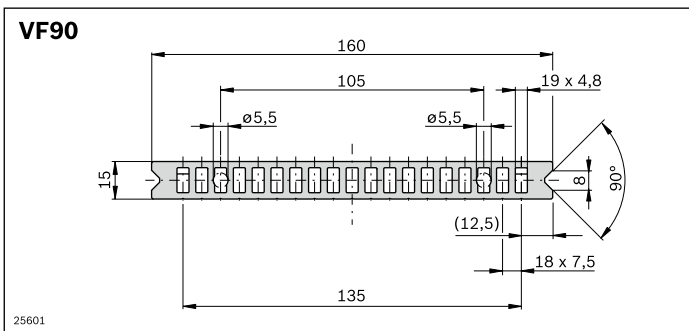
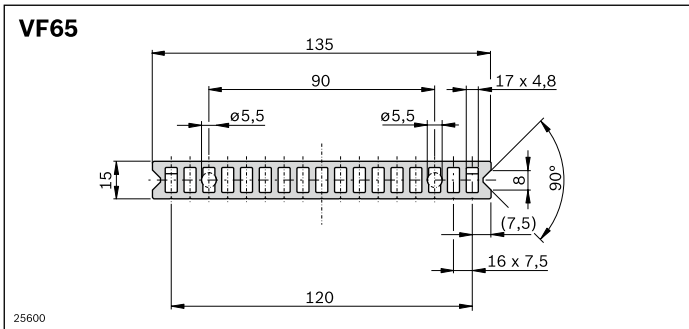

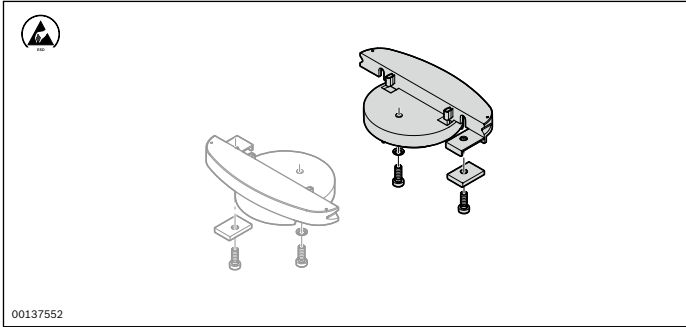

End piece	No.
VFplus 65	10 3 842 541 902
VFplus 90	10 3 842 541 903

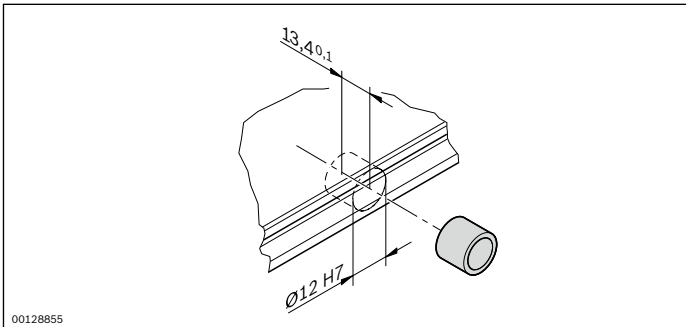

Centering bushing	No.
	1 3 842 535 081