

Drilling jig

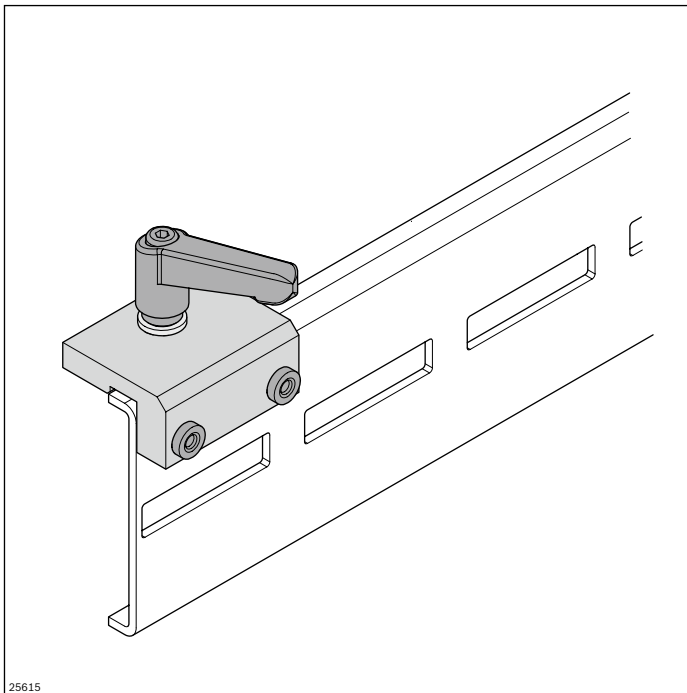

The drilling jig can be right- or left-justified and is used to drill an accurately positioned hole to secure the slide rail both on the section profile as well as on the support profile.

Drilling jig	No.
	3 842 553 518

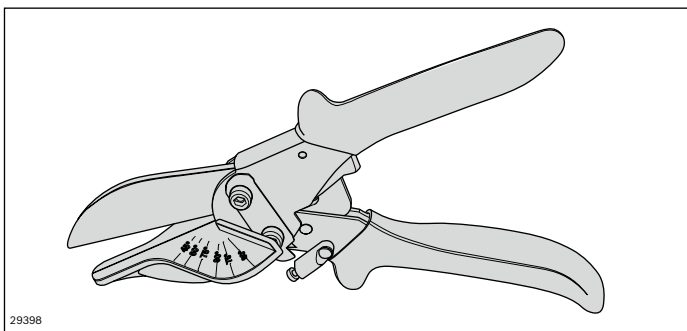

The slide rail can be easily and quickly cut to the correct length and angle with the miter cutter.

Miter cutter	No.
	3 842 547 982

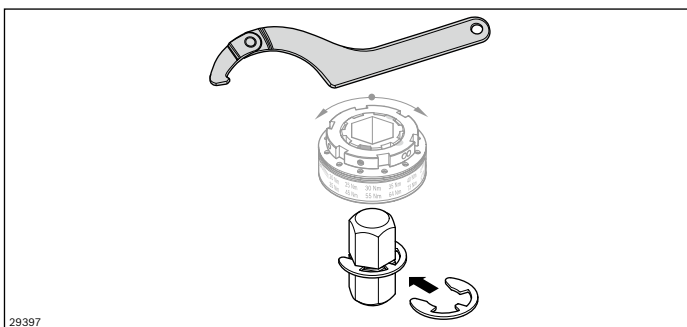

Tool for setting the customer-specific torque of the optionally available safety coupling of the drive kit.

Safety coupling tool	No.
	3 842 549 388