

Strut profiles

With more than 100 strut profiles for all types of loadings, Bosch Rexroth AG offers the widest product range for different requirements:

- ▶ Square and rectangular profiles
- ▶ Light profiles with optimized cross-sections
- ▶ Round profiles and profiles with smooth lateral surfaces

Connectors with high load-bearing capacities combined with ultra robust slots and large central bores make profile connections possible which can handle high static and dynamic loads.

Bosch Rexroth AG offers you 6 different profile ranges. All profiles within a profile range have the same slot dimensions and spacing so as to ensure that everything always fits together perfectly during construction. As they are very sturdy, the profiles with a 10 mm slot are suitable for building structures ranging from tables to heavy machine frames. They are available in four profile series with a slot spacing of 40 mm, 45 mm, 50 mm, or 60 mm.



The profiles with 8 mm and 6 mm slots are used in the construction of lightweight equipment, partition walls, stands, or showcases.

Profile length in profile packaging units

The stated length of the profile packaging units relates to the guaranteed usable length.

During anodizing as part of the manufacturing process bare areas which are approx. 30 mm long are left at each end of the profile (= contact areas), so the profiles are generally supplied incorporating an excess length of 100 mm.

Example:

45x45L		L (mm) No.	
	20 pcs		6070 3 842 553 611

Note: The length dimension “L” in the table equals the usable length, whereas the actual length is approx. 100 mm longer.

Strut profiles – slot sizes and modular dimensions

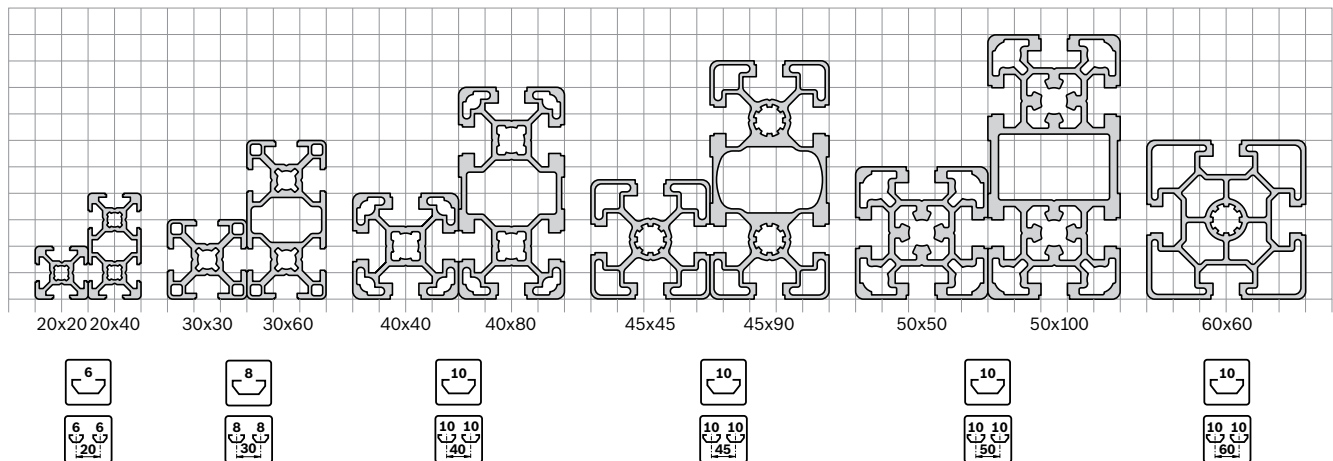

00111714

Strut profiles – slot sizes and modular dimensions

6 mm slot, 20 mm modular dimension

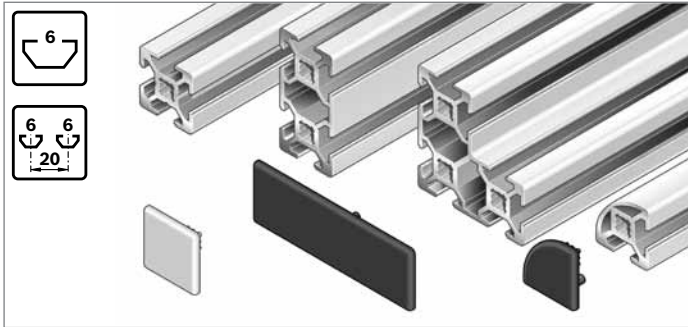

8 mm slot, 30 mm modular dimension

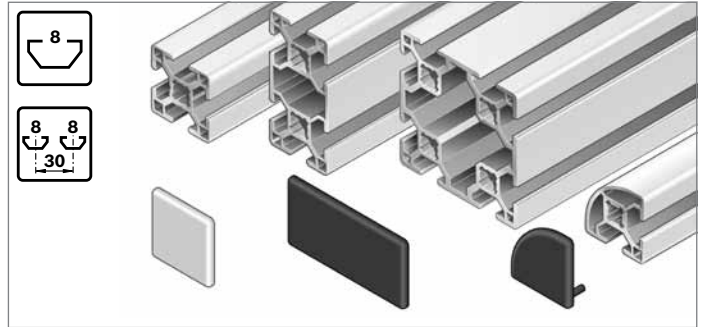

10 mm slot, 40 mm modular dimension

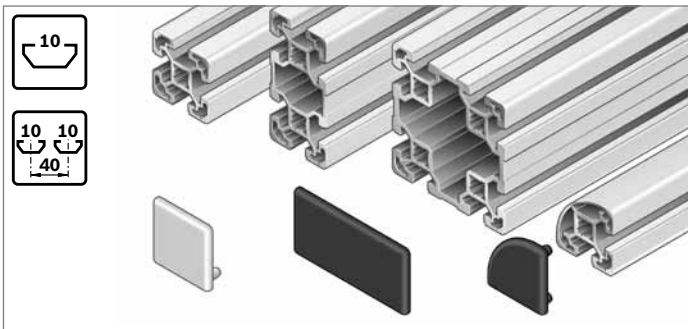

10 mm slot, 45 mm modular dimension

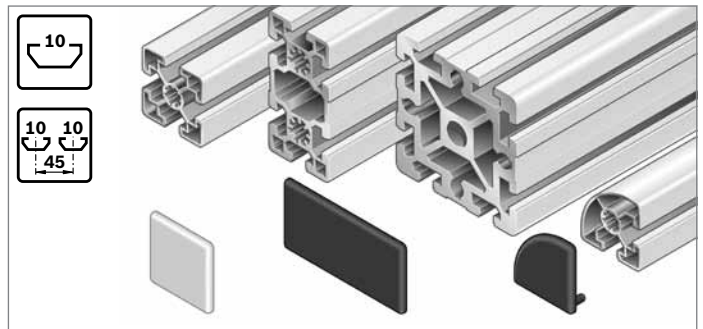



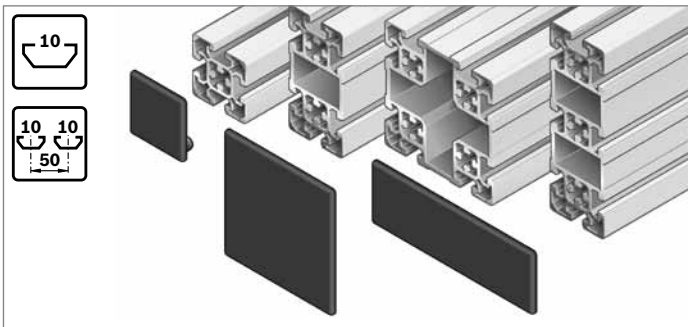



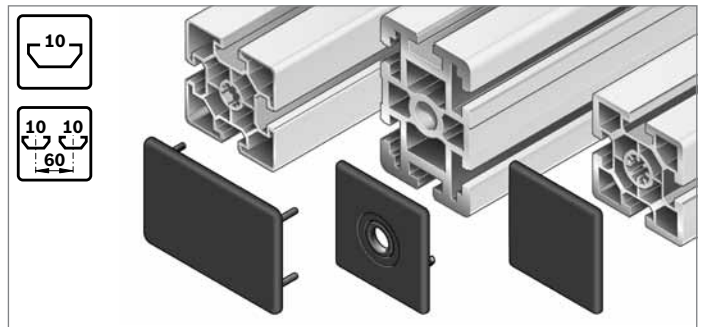































10 mm slot, 50 mm modular dimension























































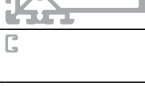

10 mm slot, 60 mm modular dimension





























Technical data – profiles

Profile	Groove	Profile surface	Moment of inertia		Moment of resistance		Torsion index		Mass	Page	
			A (cm ²)	I _x (cm ⁴)	I _y (cm ⁴)	W _x (cm ³)	W _y (cm ³)	I _t (cm ⁴)			W _t (cm ³)
20x20		6	1.6	0.7	0.7	0.7	0.7	0.08	0.17	0.4	2-12
20x20 1N		6	1.9	0.8	0.8	0.8	0.8	0.60	0.67	0.5	2-12
20x20 2N		6	1.8	0.7	0.8	0.7	0.8	0.31	0.52	0.5	2-12
20x20 2NVS		6	1.8	0.7	0.7	0.7	0.7	0.37	0.52	0.5	2-13
20x20 3N		6	1.7	0.7	0.8	0.7	0.7	0.19	0.34	0.5	2-13
20x20 R		6	1.6	0.6	0.6	0.5	0.5	0.21	0.39	0.4	2-13
20x40		6	2.9	4.6	1.2	2.5	1.4	0.68	0.91	0.8	2-14
20x60		6	3.5	14.2	1.7	4.7	1.7	2.30	2.00	0.9	2-14
20x40x40		6	4.2	6.0	6.0	2.6	2.6	1.50	1.30	1.1	2-14
10x40		6	2.1	3.2	0.2	1.6	0.4	-	-	0.6	2-15
30x30		8	3.1	2.8	2.8	1.8	1.8	0.29	0.33	0.9	2-17
30x30 1N		8	3.7	3.1	3.5	2.0	2.3	2.80	1.50	1.0	2-17
30x30 2N		8	3.5	2.8	3.5	2.1	2.7	1.50	1.20	1.0	2-17
30x30 2NVS		8	3.5	3.1	3.1	2.0	2.0	1.70	1.10	1.0	2-18
30x30 3N		8	3.3	3.1	2.8	2.3	2.1	0.86	0.73	0.9	2-18
30x30°		8	3.7	3.5	3.6	2.0	1.9	1.50	2.00	1.0	2-18
30x45°		8	4.0	3.6	5.1	2.1	2.3	2.10	2.40	1.1	2-19
30x60°		8	3.6	3.0	4.1	1.7	1.9	1.50	2.00	1.0	2-19
30x30 R		8	2.9	2.3	2.3	1.4	1.4	0.81	1.20	0.8	2-19
30x60		8	5.5	19.6	5.1	7.0	3.9	2.60	2.10	1.5	2-20
30x60 4N		8	5.8	20.2	5.5	6.7	3.8	4.80	2.40	1.6	2-20
30x60x60		8	8.2	26.2	26.2	7.6	7.6	6.40	3.60	2.2	2-20
30x90		8	7.7	60.7	7.3	13.5	4.9	5.10	3.80	2.1	2-21
30x120		8	9.9	136.3	9.6	22.7	6.4	7.60	5.60	2.7	2-21
30x45		8/10	4.0	8.1	3.9	3.9	2.9	1.30	1.30	1.1	2-22
60x60 8N		8	9.8	39.7	39.7	13.2	13.2	19.30	6.80	2.6	2-22
11x20		8	1.0	0.5	0.1	0.7	0.3	-	-	0.3	2-22
15x120		8	9.0	110.4	2.2	18.4	2.7	-	-	2.4	2-23
40x40L		10	5.6	9.1	9.1	4.5	4.5	1.30	0.74	1.5	2-26
40x40L 0N		10	6.3	10.4	10.4	5.2	5.2	10.70	4.30	1.7	2-26
40x40L 1N		10	6.1	9.8	10.3	4.7	5.1	6.90	3.70	1.7	2-26
40x40L 2N		10	6.0	9.0	10.3	4.5	5.2	4.00	3.00	1.6	2-27
40x40L 2NVS		10	6.0	9.7	9.7	4.9	4.9	4.50	2.70	1.6	2-27
40x40L 3N		10	5.8	9.7	9.0	4.8	4.5	2.60	1.70	1.6	2-27
40x30°		10	6.2	9.4	11.8	4.7	5.9	3.00	3.10	1.7	2-28
40x45°		10	6.8	9.9	16.6	5.0	8.3	4.20	3.70	1.8	2-28
40x60°		10	6.3	8.7	13.1	4.3	6.5	3.00	3.10	1.7	2-28
40x40L R		10	5.0	7.2	7.2	3.6	3.6	2.50	2.00	1.3	2-29
40x40 HR		10	5.5	8.1	7.6	4.0	3.6	4.60	2.80	1.5	2-29

Profile	Groove	Profile surface	Moment of inertia			Moment of resistance		Torsion index		Mass	Page
			A (cm ²)	I _x (cm ⁴)	I _y (cm ⁴)	W _x (cm ³)	W _y (cm ³)	I _t (cm ⁴)	W _t (cm ³)		
40x80L		10	9.9	63.4	17.3	15.9	8.7	8.02	4.80	2.7	2-30
40x80L 2N		10	10.9	66.6	20.8	16.6	10.4	22.40	7.58	2.9	2-30
40x80L 4N		10	10.4	65.2	19.1	16.3	9.9	13.30	4.40	2.8	2-30
40x80L 2NVS		10	10.7	67.8	19.0	17.0	9.5	19.24	7.55	2.9	2-31
40x80L 3NVS		10	10.6	67.8	19.0	17.0	9.5	15.90	5.20	2.9	2-31
40x80x80L		10	15.4	96.6	96.6	24.2	24.2	19.60	9.80	4.2	2-31
40x120L		10	15.5	203.2	27.8	33.9	13.9	17.20	10.00	4.2	2-32
40x160L		10	20.5	466.7	37.2	58.3	18.6	25.80	14.60	5.5	2-32
80x80L		10	18.2	132.1	132.1	33.0	33.0	59.80	17.20	4.9	2-33
80x80L 4N		10	19.3	142.5	142.5	35.6	35.6	83.90	15.4	5.2	2-33
80x80L 4NVS		10	19.3	142.5	142.5	35.6	35.6	92.00	16.80	5.2	2-34
80x80L 6N		10	18.8	134.1	140.9	33.5	36.2	72.60	15.00	5.1	2-34
40x120x120L		10	24.6	318.0	318.0	42.2	42.2	37.10	19.00	6.7	2-34
80x120L		10	25.6	389.2	192.8	64.9	48.2	119.00	29.10	6.9	2-35
80x160L		10	32.9	850.7	253.4	106.3	63.4	182.00	41.10	8.9	2-35
45x45L		10	6.0	11.7	11.7	5.2	5.2	1.46	0.75	1.6	2-36
45x45L 0N		10	6.7	13.5	13.5	6.0	6.0	16.20	6.10	1.8	2-36
45x45L 1N		10	6.5	12.6	13.5	5.5	6.0	10.00	5.20	1.8	2-37
45x45L 2N		10	6.4	11.6	13.5	5.2	6.0	5.50	4.30	1.7	2-37
45x45L 2NVS		10	6.4	12.6	12.6	5.6	5.6	6.30	3.80	1.7	2-37
45x45L 3N		10	6.2	12.6	11.7	5.4	5.2	3.40	2.40	1.7	2-38
45x30°		10	6.9	12.7	15.2	5.0	5.3	6.60	5.70	1.9	2-38
45x45°		10	7.6	13.4	21.4	5.2	6.4	9.00	6.80	2.0	2-38
45x60°		10	6.8	11.4	16.9	4.4	5.2	6.80	4.30	1.8	2-39
45x45L R		10	4.9	8.6	8.6	5.0	5.0	3.30	2.80	1.3	2-39
45x45HR		10	6.6	11.0	10.7	4.4	4.8	7.60	3.40	1.8	2-39
45x45		10	7.5	13.8	13.8	6.1	6.1	2.65	0.96	2.0	2-40
45x60		10	11.0	37.2	22.7	12.4	10.1	6.70	4.09	3.0	2-41
45x90SL		10	9.0	73.4	18.1	16.3	8.0	8.57	4.00	2.4	2-41
45x90L		10	11.3	82.0	23.6	18.2	10.5	15.10	4.40	3.0	2-42
45x90L 2N		10	12.0	85.6	26.9	38.1	6.0	31.70	7.70	3.2	2-42
45x90L 2NVS		10	12.0	25.9	90.6	5.7	40.3	23.34	9.65	3.3	2-43
45x90L 3NVS		10	11.8	87.2	25.2	38.8	5.6	25.70	6.60	3.2	2-43

Profile	Groove	Profile surface	Moment of inertia		Moment of resistance		Torsion index		Mass m (kg/m)	Page	
			A (cm ²)	I _x (cm ⁴)	I _y (cm ⁴)	W _x (cm ³)	W _y (cm ³)	I _t (cm ⁴)			W _t (cm ³)
45x90		10	15.4	124.6	32.8	27.7	14.6	15.40	6.61	4.2	2-44
45x180		10	25.5	766.7	57.3	85.2	25.5	44.40	17.00	6.9	2-44
45x270		10	61.9	3962.0	118.0	300.2	61.6	-	-	16.7	2-45
45x90x90L		10	21.2	152.1	152.1	19.1	32.6	34.90	11.60	5.7	2-45
45x90x90L 4N		10	22.1	160.8	160.8	30.6	30.6	65.30	17.20	6.0	2-46
90x90SL		10	14.1	130.2	130.2	28.9	28.9	42.50	13.90	3.8	2-46
90x90L		10	24.1	211.1	211.1	46.9	46.9	82.10	20.10	6.5	2-46
90x90L 4N		10	24.2	227.4	214.7	50.5	47.7	122.00	22.20	6.5	2-47
90x90L 4NVS		10	24.2	220.9	220.9	49.2	49.2	127.00	22.00	6.5	2-47
90x90		10	38.4	299.8	299.8	66.7	66.7	118.60	26.00	10.4	2-47
90x180L		10	42.8	1380.0	401.0	153.3	89.1	257.00	47.10	11.6	2-48
90x180		10	63.6	2138.3	544.3	237.6	121.0	429.00	64.00	17.2	2-48
90x360		10	90.2	14065.0	710.0	781.4	157.7	937.10	117.60	24.4	2-49
15x22.5		10	1.3	0.8	0.3	0.9	0.6	-	-	0.3	2-49
15x180		10	11.6	321.7	3.2	35.7	4.2	-	-	3.1	2-50
22.5x45		10	4.7	7.1	2.9	3.2	2.6	-	-	1.3	2-50
22.5x180		10	21.6	581.0	11.8	66.8	14.7	-	-	5.8	2-50
50x50L		10	9.3	21.2	21.2	8.5	8.5	5.37	4.30	2.5	2-51
50x100L		10	17.2	162.8	42.6	32.6	17.0	29.43	10.70	4.6	2-51
50x150L		10	25.8	540.0	64.2	72.0	25.7	52.10	20.50	6.9	2-52
100x100L		10	29.9	318.3	318.3	63.7	63.7	153.53	31.40	8.1	2-52
100x200L		10	54.0	2133.1	602.1	213.3	120.4	421.00	75.70	14.6	2-53

Profile	Groove	Profile surface	Moment of inertia			Moment of resistance		Torsion index		Mass m (kg/m)	Page
			A (cm ²)	I _x (cm ⁴)	I _y (cm ⁴)	W _x (cm ³)	W _y (cm ³)	I _t (cm ⁴)	W _t (cm ³)		
60x60L		10	9.6	32.4	32.4	10.8	10.8	13.20	8.70	2.6	2-53
60x60		10	14.4	52.2	52.2	17.4	17.4	15.90	8.80	3.9	2-54
60x90		10	25.8	214.2	90.5	47.6	30.2	45.80	18.00	7.0	2-54
50x50 Rectangular tube		10	4.5	15.1	15.1	5.7	5.7	-	-	1.2	2-55
Frame profile 22.5x30		10	3.2	1.7	3.0	1.5	2.0	-	-	0.9	2-57
Frame profile 22.5x45		10	3.4	6.7	1.7	2.8	1.3	-	-	0.9	2-58
Angle profile		10	4.5	8.8	6.9	3.2	2.3	-	-	1.2	2-59
Suspension profile		10	2.0	2.0	0.5	2.7	0.3	-	-	0.6	2-60
30x100 L/R Grooved plate		10	9.7	88.8	9.2	17.8	6.0	-	-	2.6	2-62
30x100 M Grooved plate		10	9.7	88.8	9.2	17.8	6.0	-	-	2.6	2-62
Profile rail 30x45C		10	4.4	10.3	5.6	4.2	3.7	-	-	1.2	2-65
U-profile		10	4.4	10.4	8.3	4.6	4.1	-	-	1.2	2-66
SP 2/R		8	5.2	4.3	11.7	2.4	5.2	-	-	1.4	2-66
SP 2/B		10	10.4	49.6	25.8	12.1	11.5	-	-	2.8	2-67
SP 2/B-50		8/10	6.9	16.1	16.9	5.3	7.5	-	-	1.9	2-67
SP 2/B-100		10	11.9	95.1	30.4	20.0	13.5	-	-	3.2	2-67
SP 2/BH		10	12.4	53.7	28.6	14.0	13.8	-	-	3.3	2-68
SP 4/R		10	26.1	222.0	95.5	84.9	16.4	-	-	3.5	2-68
D28			2.4	1.5	1.5	1.1	1.1	-	-	0.7	2-70
D28x55			5.9	3.2	88.3	2.3	32.1	-	-	1.6	2-71
D28L			1.8	1.3	1.3	1.0	1.0	-	-	0.5	2-74
D28L; N10			2.6	1.2	2.0	0.8	1.4	-	-	0.7	2-74
Section profile MV45x45		10	6.2	11.8	10.5	5.3	4.7	-	-	1.7	12-28
30x30 WG30		8	3.2	2.5	3.0	1.6	1.9	-	-	0.9	10-9
30x30 WG40		8	3.2	2.4	2.9	1.5	1.8	-	-	0.9	10-9
30x45 WG30		8	4.5	7.3	4.2	3.2	2.7	-	-	1.2	10-9
30x45 WG40		8	4.5	6.9	4.1	4.3	1.8	-	-	1.2	10-9

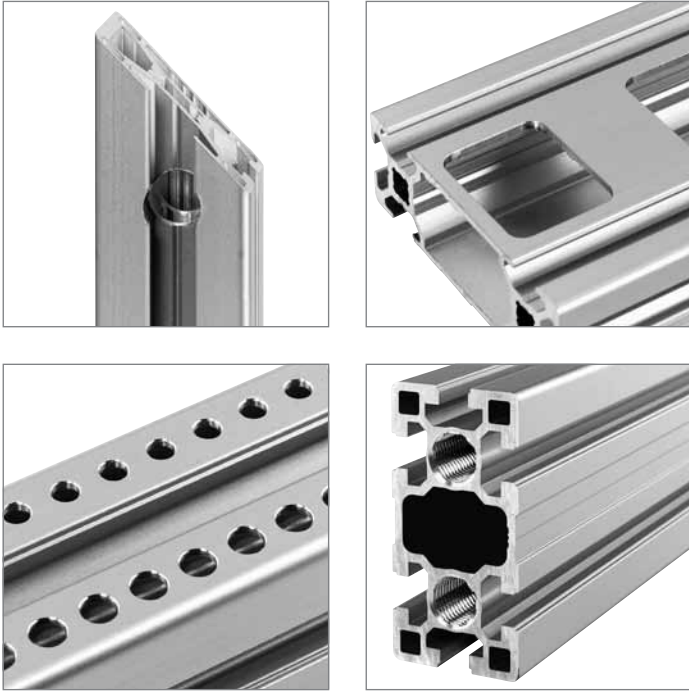

Profile finishing

Profile finishing is required whenever interlocking connectors are used. For example, holes must be drilled for bolt connectors or threads must be cut in the central hole. This requires finishes with standard dimensions. However, individual customer requirements can only be fulfilled by providing customized profile finishing wherever desired.

Rexroth enables even these complex requirements to be met as standard. This is because we offer three options for ordering the right profile finishing:

Standard profile finishing with fixed material numbers

For certain profiles, you can receive selected profile finishing with a fixed material number. This is the easiest way to order the appropriate profile finishing for our proven interlocking profile connectors.

The available profile finishing are shown in pictograms in the order tables.

Quick & Easy – standard profile finishing

All profile finishing with standard dimensions: available for all profiles thanks to simple configuration with Quick & Easy. For more information on the available profile finishing, see the fold-out section at the end of the catalog.

Quick & Easy – individual profile finishing

Get the greatest possible flexibility in defining your profile finishing. Individual finishing options can be achieved in virtually any combination and nearly every point along the profile.

For more information, see the fold-out section at the end of the catalog.

Example: 40x40L

3 842 993 126 / 255 D17  D17V

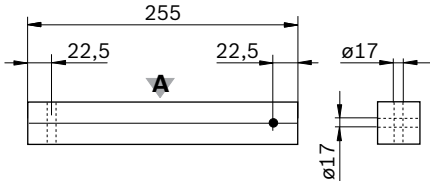

00133799

Example: 40x40L 2N

3 842 993 720 / 255 /
A=D17/-; B=-/D17

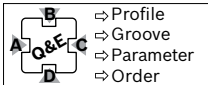
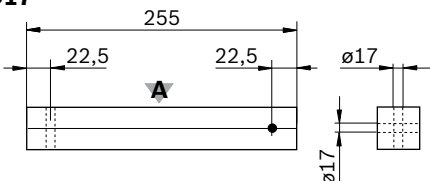
00133800

Example: 20x60

3 842 993 698 / 255 /
[B=D1; PS=58; OS=20; DM=9,8]

00133801

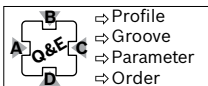
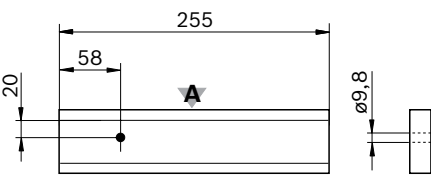

eShop and MTpro – software tools for designers, planners, and purchasers

Quick & Easy is supported by Rexroth’s eShop and the MTpro profile configurator.

We offer:

- ▶ Customer-friendly configuration
- ▶ Generation of 3D CAD models for designers
- ▶ Drawings at the press of a button
- ▶ Integration of frames/profiles in layouts
- ▶ Easy ordering at the click of a mouse

45x90L
3 842 993 662

3 842 993 662	/ 393	/ B = D17/-
Material number	Length	Standard finishing through-hole D17 in slot B

Quick & Easy – four steps for simple ordering

The type of profile finishing is defined in an order key; all finishes for a profile can be summarized in one order key.

1. Select profile cross-section and length
2. Specify slot for finishing: all profile slots are identified by letters (A; B; C; ...) – ascending in clockwise direction (see profile dimension drawings)
3. Define the parameters:
 - type of finishing (drilling, milling, miter cutting)
 - Distance from profile end face
4. Place order: conventionally by fax or, preferably online in our eShop

Logical structure of the order key
Material number/length/[slot designation = finishing; parameter set]

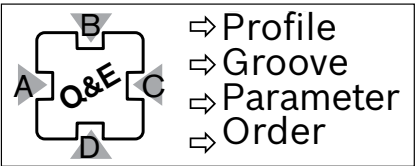

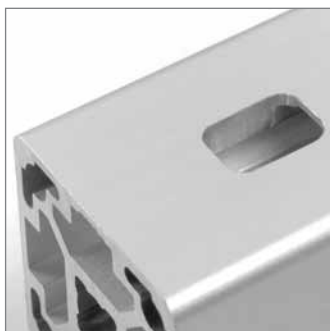
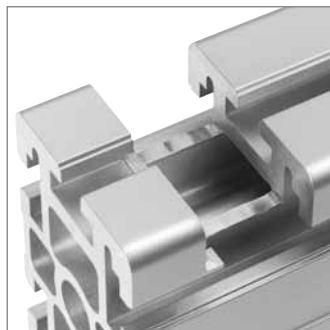

Profile finishing

Rexroth offers you numerous connection options for putting strut profiles together.

The wide variety of connector types is due to the differing demands made of the applications:

- ▶ Right-angled
- ▶ Variable-angle
- ▶ Internal
- ▶ Torsion-resistant
- ▶ Vibration-resistant
- ▶ With or without profile finishing

If you require a finished profile, it can be provided for you in an installation-ready form.

When you select the corresponding material number the profile is provided in cut, burr-free form, or alternatively fully finished with drilled holes or threads.

This eliminates risk for you and reduces your production workload.

If you wish to undertake the finishing yourself, here are a few tips:

Saw and saw blade

Segmental metal circular saw blade, carbide-tipped

Number of teeth: 92 or 96

Rotational speed: at least 2500 rpm

Finishing of central holes

As a rule, the threads can be directly formed and cut, but countersinks facilitate their production. The central holes of the strut profiles are designed for the following thread manufacturing processes.

Threads	Finish	Note
M6	Thread forming	–
M8	Thread forming	–
M12	Thread cutting	–
M16	Thread forming	pre-drilling in some cases

Drilling jigs

In the tools section you will find useful drilling jigs for the Rexroth standard finishes (p. 14-2).

Technical data for strut profiles

EN AW – Al MgSi		Material designation according to DIN EN 573 for Rexroth strut profiles
EN AW – 6060		Material number according to DIN EN 573
R_m	= 245 N/mm ²	Minimum tensile strength (in direction of pressure)
$R_{p0,2}$	= 195 N/mm ²	0.2% proof stress (in direction of pressure)
A_5	= 10%	Ductile yield A_5 or A_{10}
A_{10}	= 8 %	
E	= 70000 N/mm ²	Modulus of elasticity E
75 HB		Brinell hardness
$\alpha_{(-50...+20\text{ °C})}$	= 21.8 x 10 ⁻⁶ 1/K	Longitudinal expansion coefficient
$\alpha_{(+20...100\text{ °C})}$	= 23.4 x 10 ⁻⁶ 1/K	

μ = 0.34 Poisson's ratio

E6/EV1 - 12 μm - 300 HV Anodizing process – layer thickness – layer hardness

L_{max}	11-20	22.5-30	40	45-60	Permitted dimensional tolerance t (mm) for profiles from different deliveries
t	± 0.15	± 0.2	+0.6	± 0.3	

L_{max}	80	90	120	160
t	+0.8	± 0.4	+1.0	+1.6

L_{max}	180	270	360
t	± 0.6	± 1.0	± 1.5

L2	6	8	10
t	+0.3	+0.3	+0.4

\emptyset	5.5	7.3	10	15
t	-0.1 +0.2	-0.1 +0.2	± 0.15	± 0.15

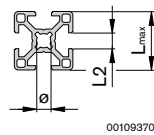

Deviation limits and form tolerances according to DIN EN 12020-2
Rexroth profiles generally fall well within the generally applicable tolerances specified in the standard. They are specifically defined for the individual products.

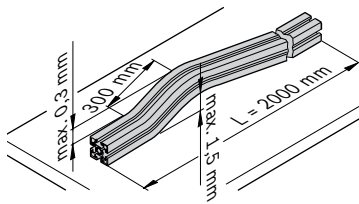

Longitudinal straightness tolerance of profile

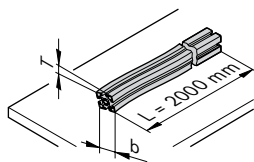

00126465

Longitudinal torsional tolerance of profile

b (mm)	T (mm)
≤ 100	1.2
100 ... 150	1.5
150 ... 200	1.8
200 ... 350	2.5

Profile deflection

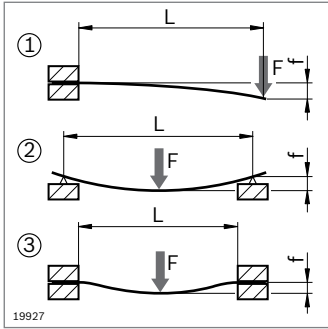

$$f_{①} = \frac{F \times L^3}{3 E \times I \times 10^4}$$

Profile deflection due to force F for static load cases ①②③

$$f_{②} = \frac{F \times L^3}{48 E \times I \times 10^4}$$

$$f_{③} = \frac{F \times L^3}{192 E \times I \times 10^4}$$

$$f_{①} = \frac{m' \times g \times L^4}{8 E \times I \times 10^4}$$

Profile deflection due to the profile's own weight

$$f_{②} = \frac{5 \times m' \times g \times L^4}{384 E \times I \times 10^4}$$

$$f_{③} = \frac{m' \times g \times L^4}{384 E \times I \times 10^4}$$

$$\sigma_{①} = \frac{(m' \times g \times L + F) \times L}{W \times 10^3}$$

Control of max. occurring bending stress $\sigma_{b \max}$

$$\sigma_{②} = \frac{(m' \times g \times L + F) \times L}{4 W \times 10^3}$$

$$\sigma_{③} = \frac{(m' \times g \times L + F) \times L}{8 W \times 10^3}$$

$$\sigma_{b \max} < \sigma_{b \text{perm}}!$$

$S_{F \text{req}}$: Safety value required to avoid deformation (flow)

$$\sigma_{b \text{perm}} = \frac{R_{p0,2}}{S_{F \text{erf}}}$$

$\sigma_{b \text{perm}}$: Max. permissible bending stress

f (mm)

W (cm³)

F (N)

E = 70000 N/mm²

L (mm)

m' (kg/mm); m' = m/1000; m (p. 2-4 ... 2-7)

I (cm⁴)

g = 9.81 m/s² ≈ 10 m/s²