

26784

EcoSlide

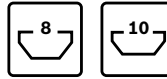

- ▶ Economical linear sliding carriage for horizontal applications
- ▶ Runs on sliders for maximal load capacity
- ▶ Slider with low moisture absorption, suitable for rough usage conditions
- ▶ Available for profile widths of 30/45/60/90
- ▶ Clamping lever (optional) for arresting in any position
- ▶ Easy to assemble
- ▶ Spacer washer for tolerance adjustment (carriage/profile)

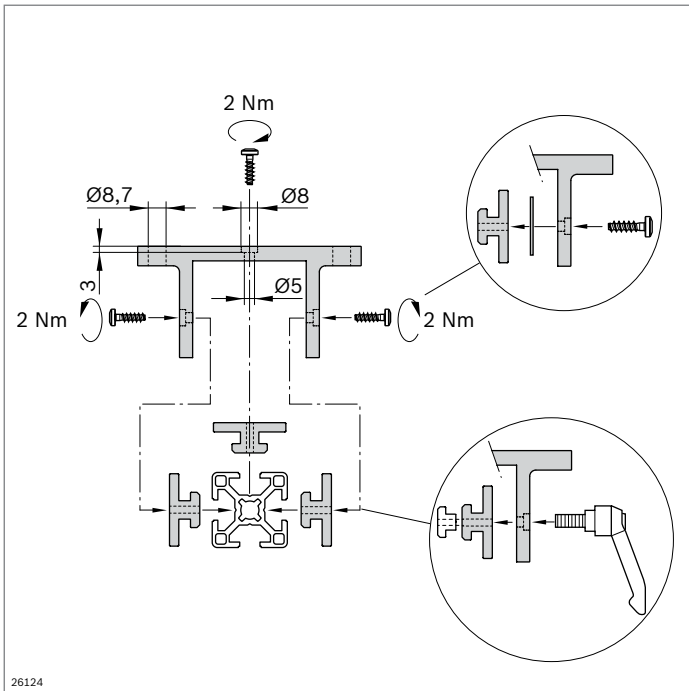

26124

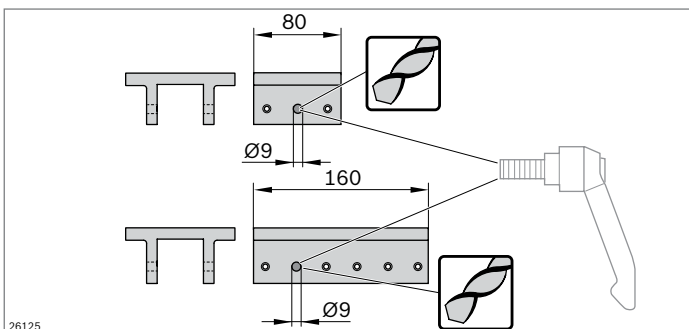

26125

Machining tip

To install the clamping lever, the corresponding 9 mm hole must be drilled in the trolley.

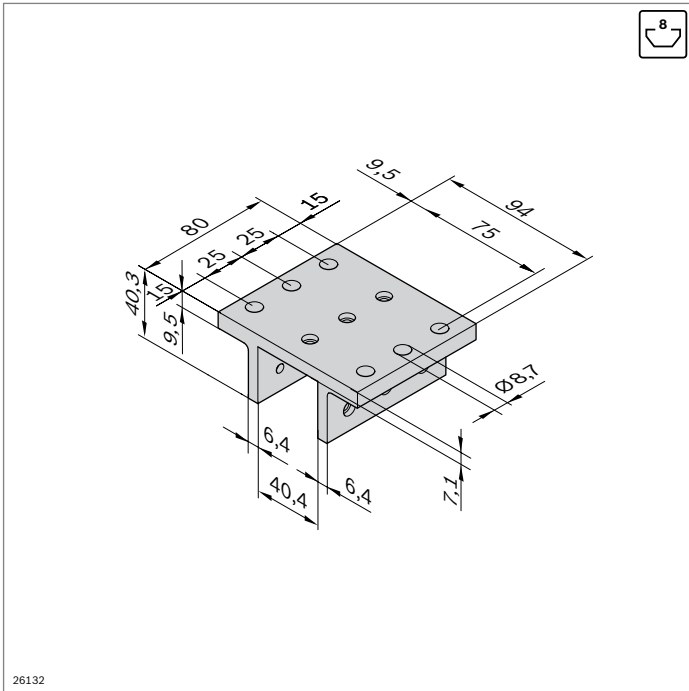

26132

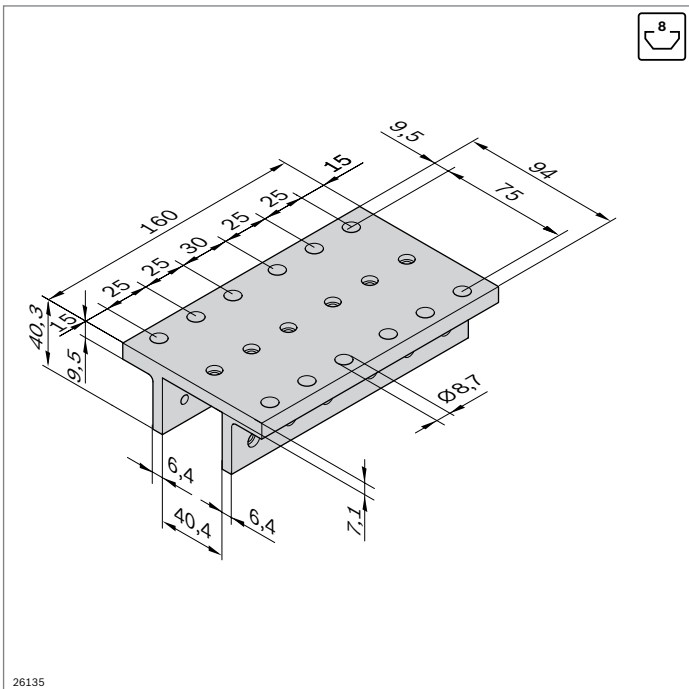
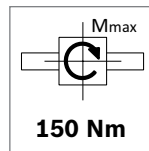
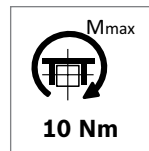
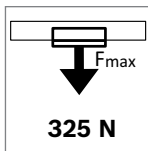
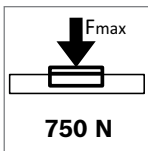

26135

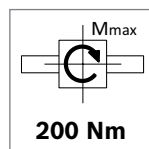
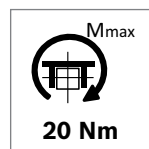
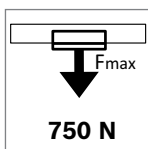
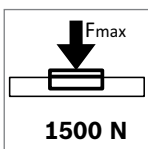

EcoSlide 30x30x80

- ▶ For use with profile width 30 mm
- ▶ Maximum sliding speed: 12 m/min

Trolley 30x30x80

	No.
	1 8 981 535 476

Material: aluminum, anodized

Accessories

	No.		Qty.	Qty.	Page
Slider, slot 8 mm flat	10	3 842 523 212	3	2	12-13
Slider, slot 8 mm flat lockable	1	3 842 552 423	—	1	12-11
Spacer washer Slot 8 mm	4	8 981 535 891	X ¹⁾	X ¹⁾	12-11
Screw W1451 - 3.5x14 - 10.9	10	3 842 552 421	9	8	12-12
Clamping lever, 20 mm	1	3 842 516 846	—	1	4-11
Sliding block Slot 8 mm; M8	100	3 842 514 931	—	1	3-7

¹⁾ If required

EcoSlide 30x30x160

- ▶ For use with profile width 30 mm
- ▶ Maximum sliding speed: 12 m/min

Trolley 30x30x160

	No.
	1 8 981 535 477

Material: aluminum, anodized

Accessories

	No.		Qty.	Qty.	Page
Slider, slot 8 mm flat	10	3 842 523 212	6	5	12-13
Slider, slot 8 mm flat lockable	1	3 842 552 423	—	1	12-11
Compensation washer Slot 8 mm	4	8 981 535 891	X ¹⁾	X ¹⁾	12-11
Screw W1451 - 3.5x14 - 10.9	10	3 842 552 421	18	17	12-12
Clamping lever, 20 mm	1	3 842 516 846	—	1	4-11
Sliding block Slot 8 mm; M8	100	3 842 514 931	—	1	3-7

¹⁾ If required

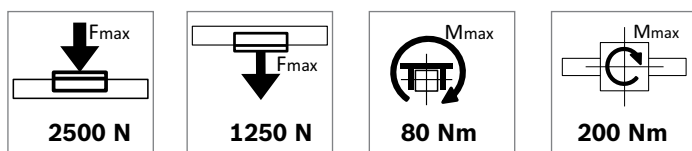
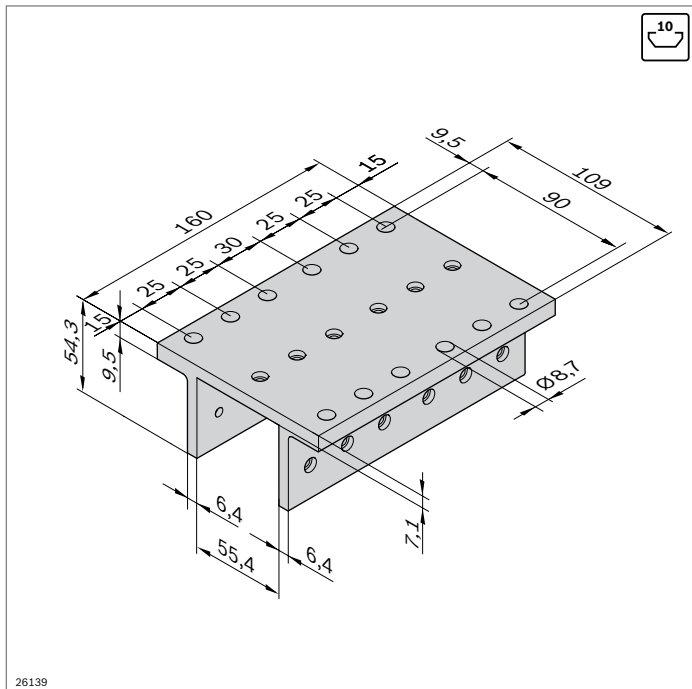
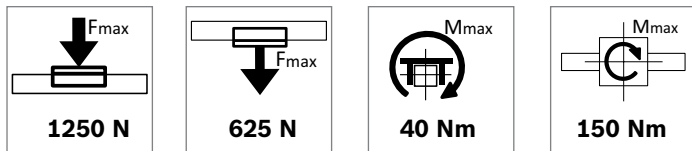
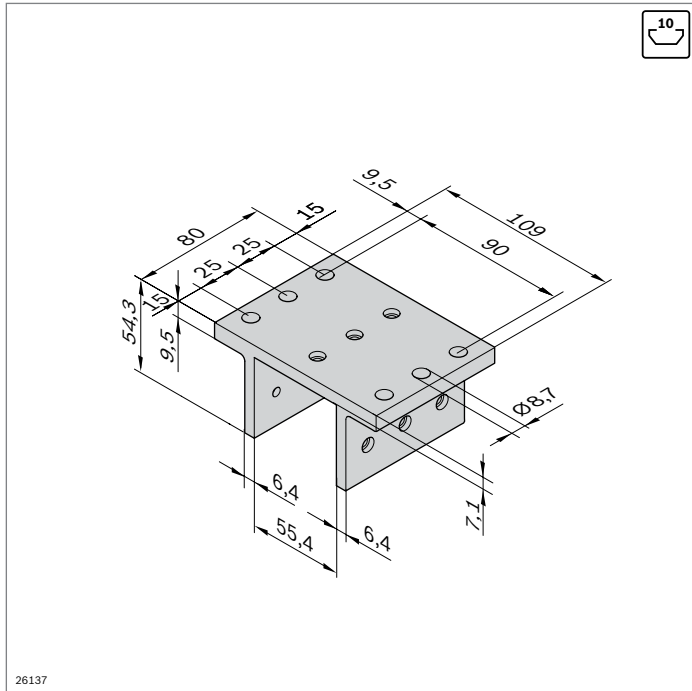

EcoSlide 45x45x80

- ▶ For use with profile width 45 mm
- ▶ Maximum sliding speed: 12 m/min

Trolley 45x45x80	No.
	1 8 981 535 323

Material: aluminum, anodized

Accessories

	No.	Qty.	Qty.	Page
Slider, slot 10 mm flat	10 3 842 530 329	3	2	12-13
Slider, slot 10 mm flat lockable	1 3 842 552 424	—	1	12-11
Compensation washer Slot 10 mm	4 8 981 535 890	X ¹⁾	X ¹⁾	12-12
Screw W1452 - 4x18 - 10.9	10 3 842 552 422	9	8	12-12
Clamping lever, 20 mm	1 3 842 516 846	—	1	4-11
Sliding block Slot 10 mm; M8	100 3 842 528 735	—	1	3-7

¹⁾ If required

EcoSlide 45x45x160

- ▶ For use with profile width 45 mm
- ▶ Maximum sliding speed: 12 m/min

Trolley 45x45x160	No.
	1 8 981 535 324

Material: aluminum, anodized

Accessories

	No.	Qty.	Qty.	Page
Slider, slot 10 mm flat	10 3 842 530 329	6	5	12-13
Slider, slot 10 mm flat lockable	1 3 842 552 424	—	1	12-11
Compensation washer Slot 10 mm	4 8 981 535 890	X ¹⁾	X ¹⁾	12-12
Screw W1452 - 4x18 - 10.9	10 3 842 552 422	18	17	12-12
Clamping lever, 20 mm	1 3 842 516 846	—	1	4-11
Sliding block Slot 10 mm; M8	100 3 842 528 735	—	1	3-7

¹⁾ If required

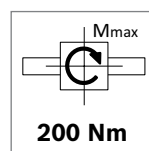
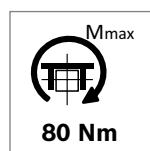
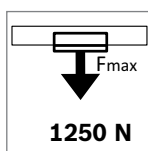
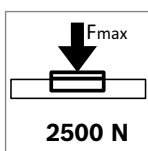
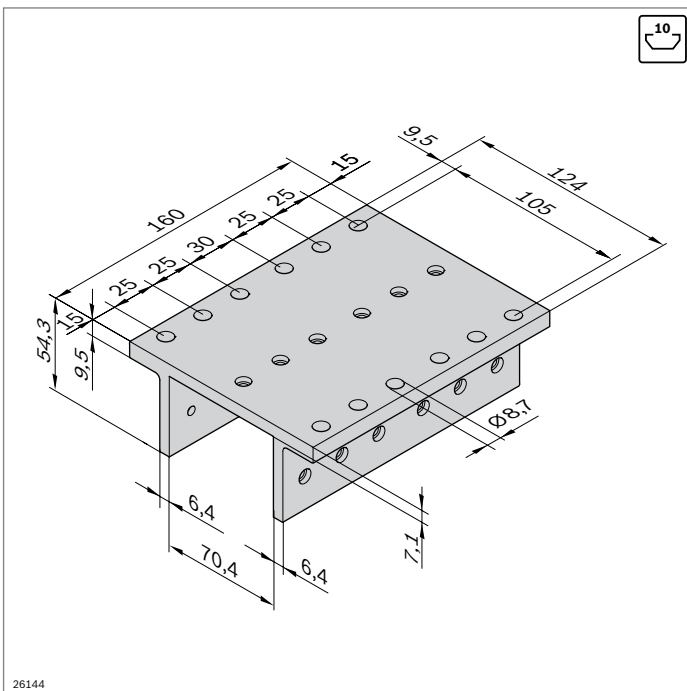
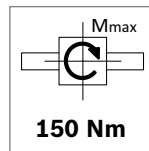
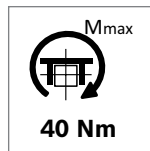
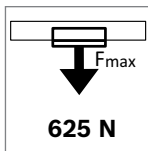
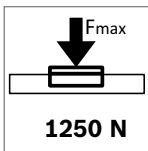
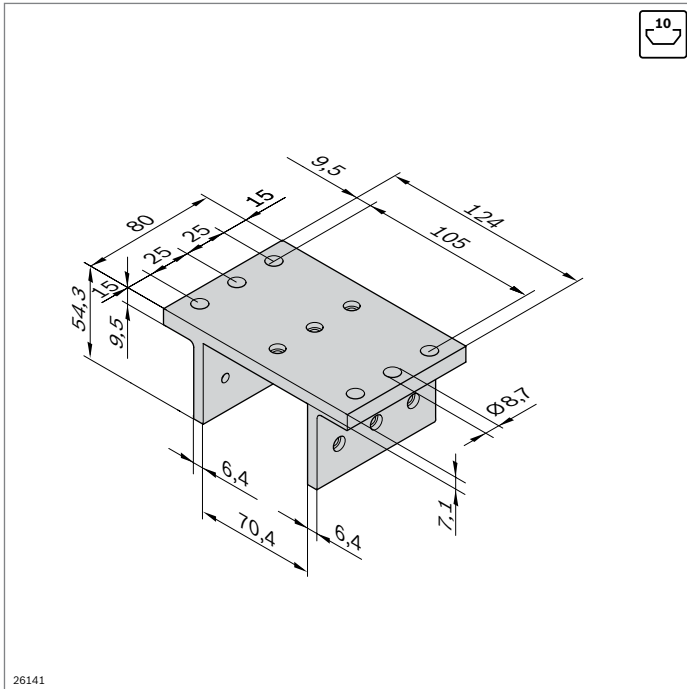

EcoSlide 45x60x80

- ▶ For use with profile width 60 mm
- ▶ Maximum sliding speed: 12 m/min

Trolley 45x60x80	No.
	1 8 981 535 478

Material: aluminum, anodized

Accessories

	No.	Qty.	Qty.	Page
Slider, slot 10 mm flat	10 3 842 530 329	3	2	12-13
Slider, slot 10 mm flat lockable	1 3 842 552 424	—	1	12-11
Compensation washer Slot 10 mm	4 8 981 535 890	X ¹⁾	X ¹⁾	12-12
Screw W1452 - 4x18 - 10.9	10 3 842 552 422	9	8	12-12
Clamping lever, 20 mm	1 3 842 516 846	—	1	4-11
Sliding block Slot 10 mm; M8	100 3 842 528 735	—	1	3-7

¹⁾ If required

EcoSlide 45x60x160

- ▶ For use with profile width 60 mm
- ▶ Maximum sliding speed: 12 m/min

Trolley 45x60x160	No.
	1 8 981 535 479

Material: aluminum, anodized

Accessories

	No.	Qty.	Qty.	Page
Slider, slot 10 mm flat	10 3 842 530 329	6	5	12-13
Slider, slot 10 mm flat lockable	1 3 842 552 424	—	1	12-11
Compensation washer Slot 10 mm	4 8 981 535 890	X ¹⁾	X ¹⁾	12-12
Screw W1452 - 4x18 - 10.9	10 3 842 552 422	18	17	12-12
Clamping lever, 20 mm	1 3 842 516 846	—	1	4-11
Sliding block Slot 10 mm; M8	100 3 842 528 735	—	1	3-7

¹⁾ If required

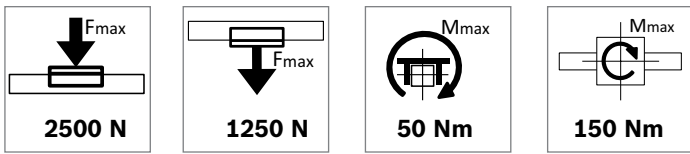
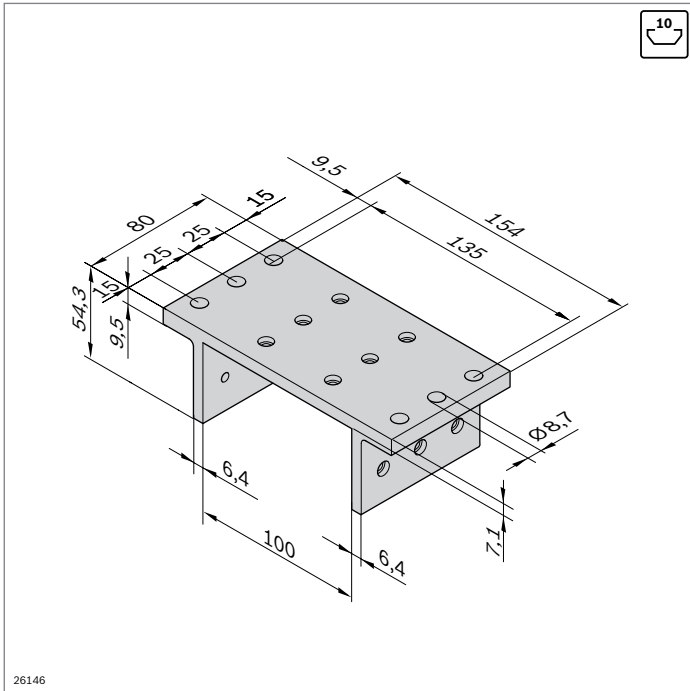

EcoSlide 45x90x80

- ▶ For use with profile width 90 mm
- ▶ Maximum sliding speed: 12 m/min

Trolley 45x90x80	No.
	1 8 981 535 325

Material: aluminum, anodized

Accessories

	No.		Qty.	Qty.	Page
Slider, slot 10 mm flat	10	3 842 530 329	4	3	12-13
Slider, slot 10 mm flat lockable	1	3 842 552 424	—	1	12-11
Compensation washer Slot 10 mm	4	8 981 535 890	X ¹⁾	X ¹⁾	12-12
Screw W1452 - 4x18 - 10.9	10	3 842 552 422	12	11	12-12
Clamping lever, 20 mm	1	3 842 516 846	—	1	4-11
Sliding block Slot 10 mm; M8	100	3 842 528 735	—	1	3-7

¹⁾ If required

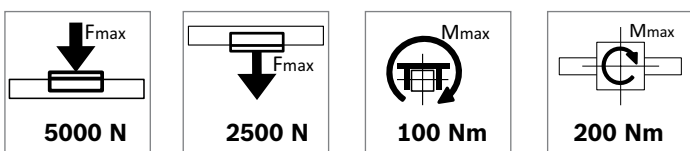
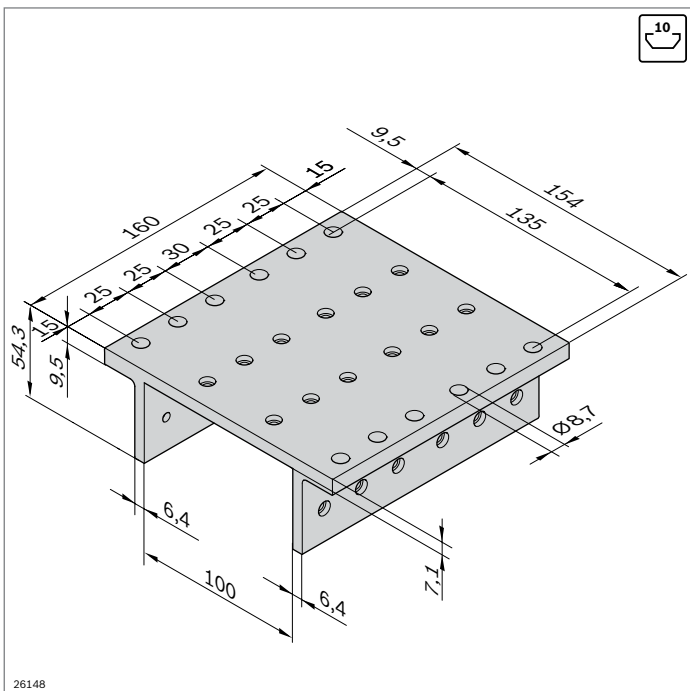

EcoSlide 45x90x160

- ▶ For use with profile width 90 mm
- ▶ Maximum sliding speed: 12 m/min

Trolley 45x90x160	No.
	1 8 981 535 326

Material: aluminum, anodized

Accessories

	No.		Qty.	Qty.	Page
Slider, slot 10 mm flat	10	3 842 530 329	8	7	12-13
Slider, slot 10 mm flat lockable	1	3 842 552 424	—	1	12-11
Compensation washer Slot 10 mm	4	8 981 535 890	X ¹⁾	X ¹⁾	12-12
Screw W1452 - 4x18 - 10.9	10	3 842 552 422	24	23	12-12
Clamping lever, 20 mm	1	3 842 516 846	—	1	4-11
Sliding block Slot 10 mm; M8	100	3 842 528 735	—	1	3-7

¹⁾ If required