

T-nut

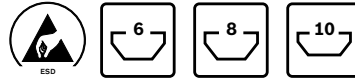



- ▶ Standard element for a secure and conductive connection
- ▶ End stop for correct positioning in the profile slot
- ▶ Stainless steel T-nut, e.g. for outdoor or cleanroom applications
- ▶ Profile finishing: not required

Technical data (p. 19-5)

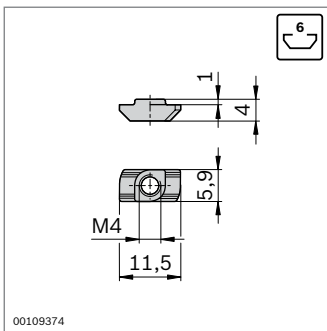
Accessories:
insulating cap (p. 3-5)







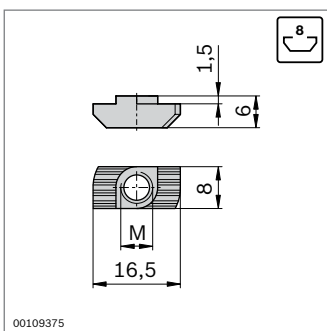

Slot	
6	1700 N

T-nut, 6 mm slot	Slot	M	ESD	No.
steel; galvanized	6	M4		100 3 842 523 135
Stainless steel	6	M4		100 3 842 536 599



Slot	
8 (M6)	4000 N





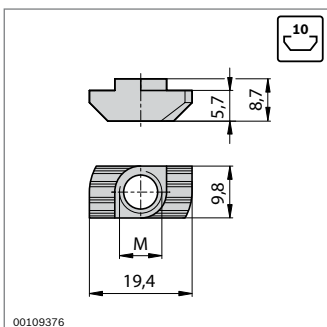



T-nut, 8 mm slot	Slot	M	ESD	No.
steel; galvanized	8	M4		100 3 842 501 751
		M5*		100 3 842 501 752
		M6*		100 3 842 501 753
Stainless steel	8	M4		100 3 842 536 600
		M5		100 3 842 536 601
		M6		100 3 842 536 602

* Suitable for flat top chains. **Caution:** T-nuts have driving torque for safe turning in the base of the slot.



Slot	
10 (M8)	6000 ... 18000 N ¹⁾

¹⁾ Depending on profile (p. 19-5)

T-nut, 10 mm slot	Slot	M	ESD	No.
steel; galvanized	10	M4		100 3 842 530 281
		M5*		100 3 842 530 283
		M6*		100 3 842 530 285
		M8*		100 3 842 530 287
Stainless steel	10	M4		100 3 842 536 606
		M5		100 3 842 536 605
		M6		100 3 842 536 604
		M8		100 3 842 536 603

* Suitable for flat top chains. **Caution:** T-nuts have driving torque for safe turning in the base of the slot.

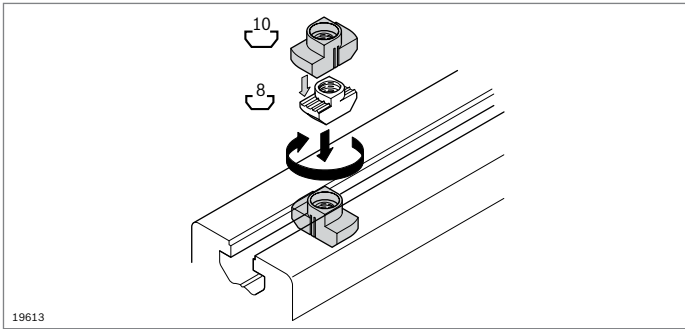

19613

- ▶ Insulating cap for decoupling directly grounded components; for use with T-nuts for 8 mm slots in a 10 mm slot

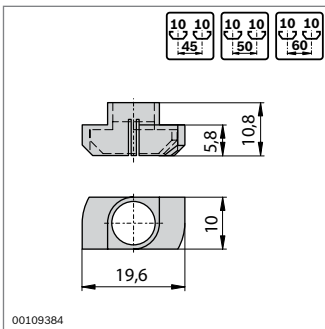

00109384

Insulating cap for T-nut, 8 mm slot	Slot	No.
	10	10 3 842 524 012

Material: high-strength PA, black

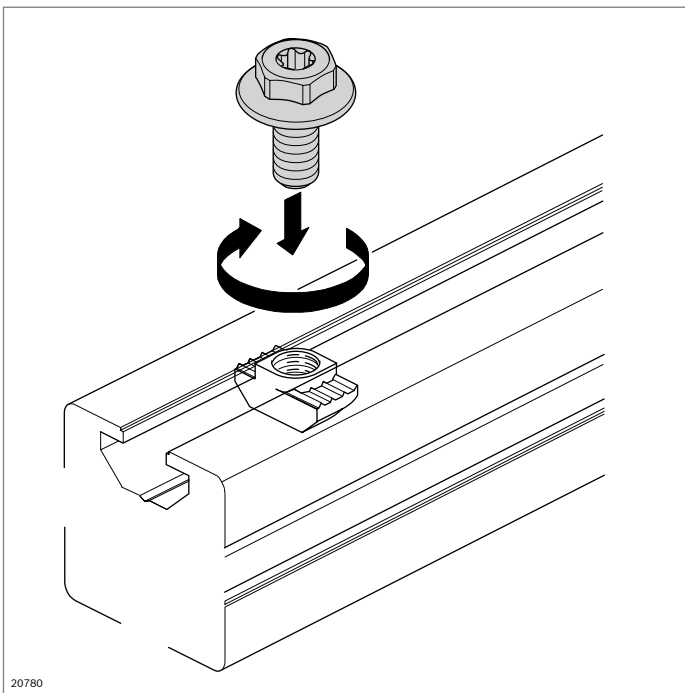

20780

Collar screw



- ▶ Collar screw with multi-functional head so that tightening with a ring / open-end wrench (WS 13) or Torx screwdriver (T40) is possible
- ▶ Machine tightening possible
- ▶ Preferably to be used for fastening brackets
- ▶ Quick and simple assembly
- ▶ Excellent force transmission via the wide flange
- ▶ ESD-capable
- ▶ With Polyfleck to secure the T-nut

Tools:
Offset screwdriver (p. 14-6)

Accessories:
T-nut (p. 3-4)

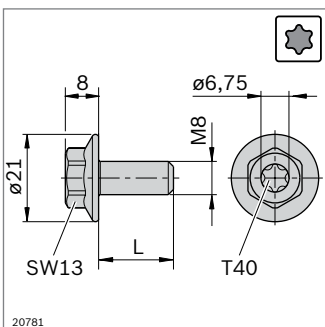

20781

Collar screw	M	L (mm)	ESD	No.
M8x18-SW13-T40¹⁾	M8	18	100	3 842 541 246
M8x20-SW13-T40²⁾	M8	20	100	3 842 541 409

¹⁾ For 40/40 and 60/60 brackets
²⁾ For all other brackets for 10 mm slot

Material: steel; galvanized